



GRITS 2009



NASA/IPAC EXTRAGALACTIC DATABASE

20 years, 163 million objects, 3.3 billion rows,
and beyond

The NED Team

Rick Ebert presenting

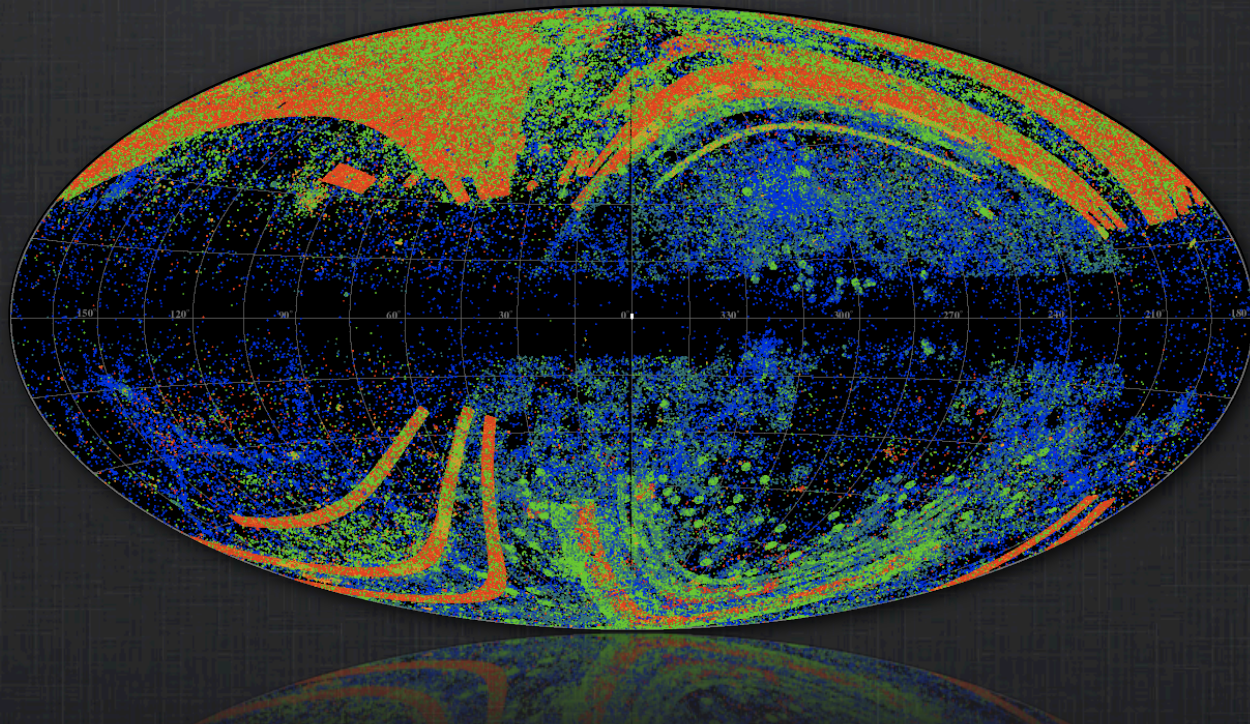



What is **NED**?

- Mission
- A brief history
 - 20 years, 3 dbms, multiple uif
- The System
 - Current holdings
 - Connections to:
 - IRSA, Google, Microsoft WWT, NVO/VAO
- The Future
 - new data sets
 - new dbms (extracting the schema, and leaving behind the one-dbms model)
 - detachable queries (backgrounding)
 - improved support for external systems

NED



NED

- NED is the world's largest database of cross-correlated multiwavelength data for extragalactic objects.
- NED provides a portal into a systematic fusion of information from:
 - hundreds of large sky surveys
 - tens of thousands of research publications.
- NED spans the observed spectrum from gamma rays through radio frequencies.
- Contents are linked to relevant data in NASA's astrophysics mission archives around the world using NED cross-ids

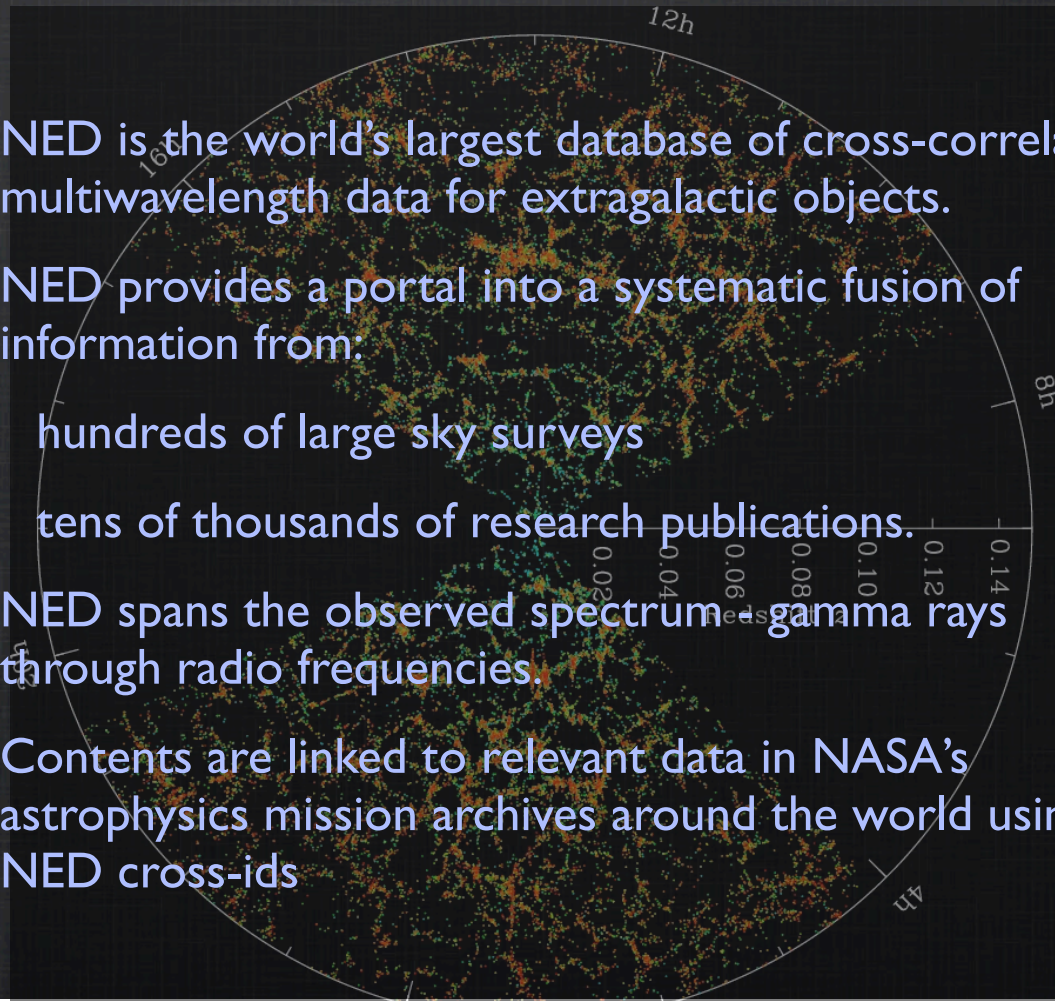



NED

the Mission

- Provide the most current, comprehensive and easy-to-use integration of multi-wavelength information for all known extragalactic objects.
- NED is a synthesis of extragalactic data spanning all NASA astrophysics missions, large sky surveys and the peer-reviewed literature.
- NED is the first port-of-call for most extragalactic researchers; and is integral to all phases of research
- NED is a cornerstone to NASA, NSF and international efforts to construct a collaborative and distributed *Virtual Observatory*



NED statistics

- Interface last updated: 16 April 2009
 - 163 million objects
 - 170 million multiwavelength object cross-IDs
 - 188 thousand associations (candidate cross-IDs)
 - 1.4 million redshifts
 - 1.7 billion photometric measurements
 - 609 million diameter measurements
 - 5.0 million objects linked to 68,354 refereed journal articles
 - 2.3 million images, maps and external links
 - 65 thousand notes
 - 45 thousand abstracts
 - 56 thousand spectra

NED



NED

NED in a nutshell



Astrophysics Literature

Objects, Measurements,
Attributes, Images,
Spectra



Individual scientists and research teams

- Interactive & automated queries
- Data Analysis & Discovery
- Publication



NED

NASA Astrophysics Mission Archives

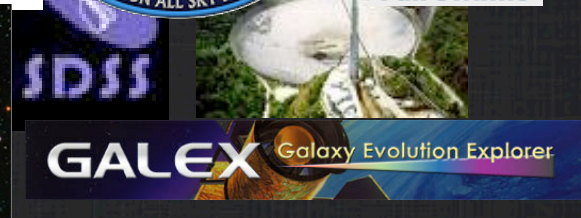
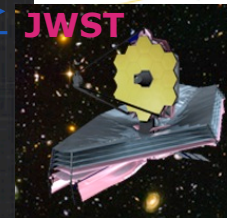
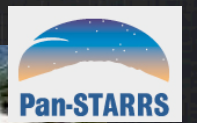
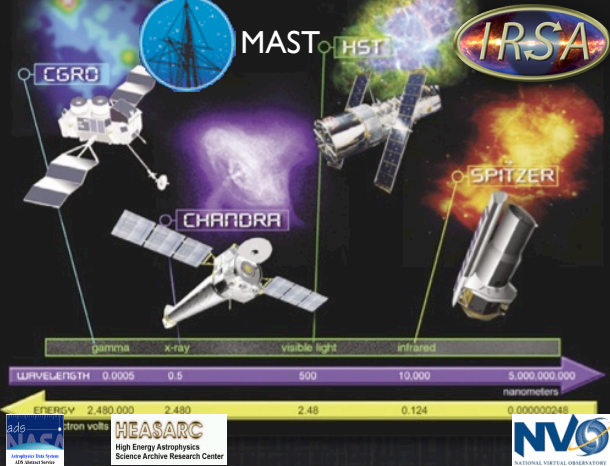

GALEX Galaxy Evolution Explorer

Sky surveys, present & future



NED

our mission

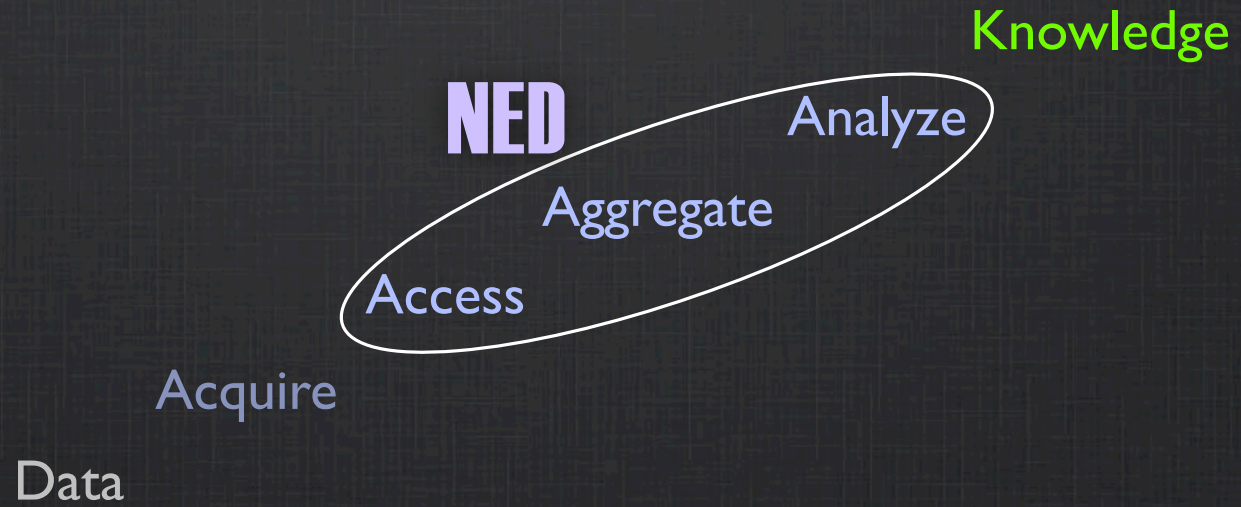



NED

a quick history

- 1985 - IPAC created
- May 1987 - Submission of NED proposal to NASA
- 1988 - CDs first marketed
- June 1990 - NED First public release
- Nov 1990 - Berners-Lee & Cailliau propose WWW
- 1991 - NED migrates from Control Data/IMDM to Sybase
- 1992 - Astrophysics Data System starts operating
- 1993 - DVD *invented*
- 1995 - NED migrates from Sybase to Informix
- 1995 - Netscape debuts/NCSA HTTPd copyright
- March 25, 1999 - Apache debuts
- Aug 25, 2003 - Spitzer Telescope launched
- June 27, 2007 - NED passes 10 million objects
- Dec 17, 2008 - NED includes SDSSdr6: 164 million
- May 14, 2009 - Herschel/Planck launched



NED

IPAC Interface to NED Preliminary Design Description

R. Ebert
October 6, 1989
Rev. October 18, 1989

Abstract

NED, the NASA/IPAC Extragalactic Database, is an electronic compendium of catalogued and researched extragalactic objects. One of the primary goals of NED is to provide access to the database by a world-wide community of researchers in Astronomy. Toward that end we present here the design of a software system to provide an approachable user interface for an astronomer wishing to access NED from a remote location using national computer networks or dial-up phone lines. Two versions of the plan are presented: a rapid implementation version intended to give minimal functionality in 2-3 months; and a more robust version that might be implemented in 8-12 months.

Introduction

The NED is a compendium of astronomical catalogue and other information



NED

IPAC Interface to NED

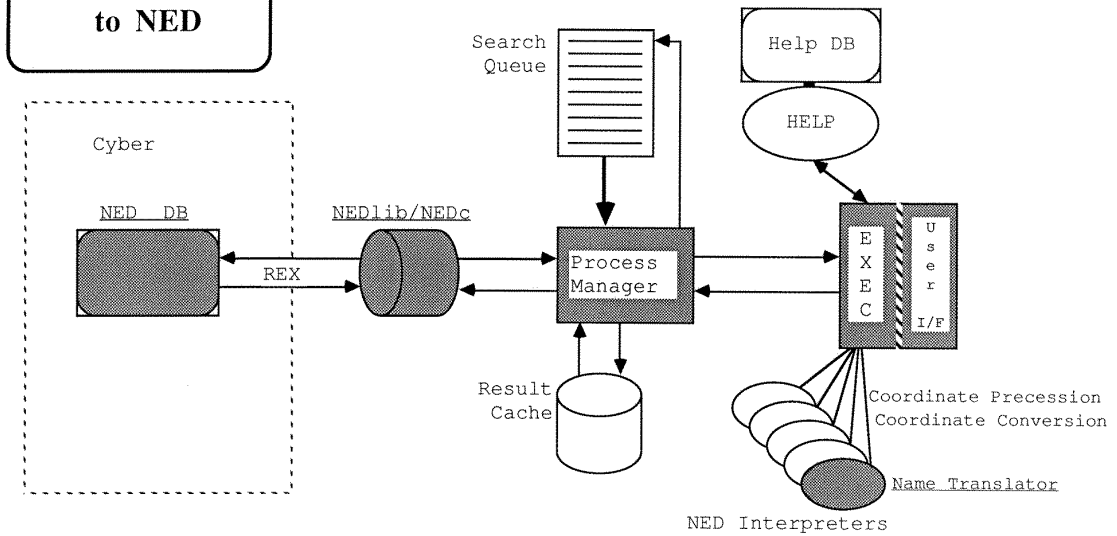

R.Ebert, 891004

Shaded portions represent minimal implementation

Name Underlined names denote inheritances



NED

Screen Dump – Fri Dec 8 18:36:30 1989

YAMM interface - 1989

0:By_Name 1:Near_Name 2:Near Position 3:Help

RA _____
Dec _____ Input Epoch 2000

Search Radius [Arc Minutes] _____

Search ^H=Help ^P=Abort data entry ^T=Next value ^L=Refresh
^E=End data entry ^D=Hardcopy TAB=Next field



NED

JAMM interface - 1993

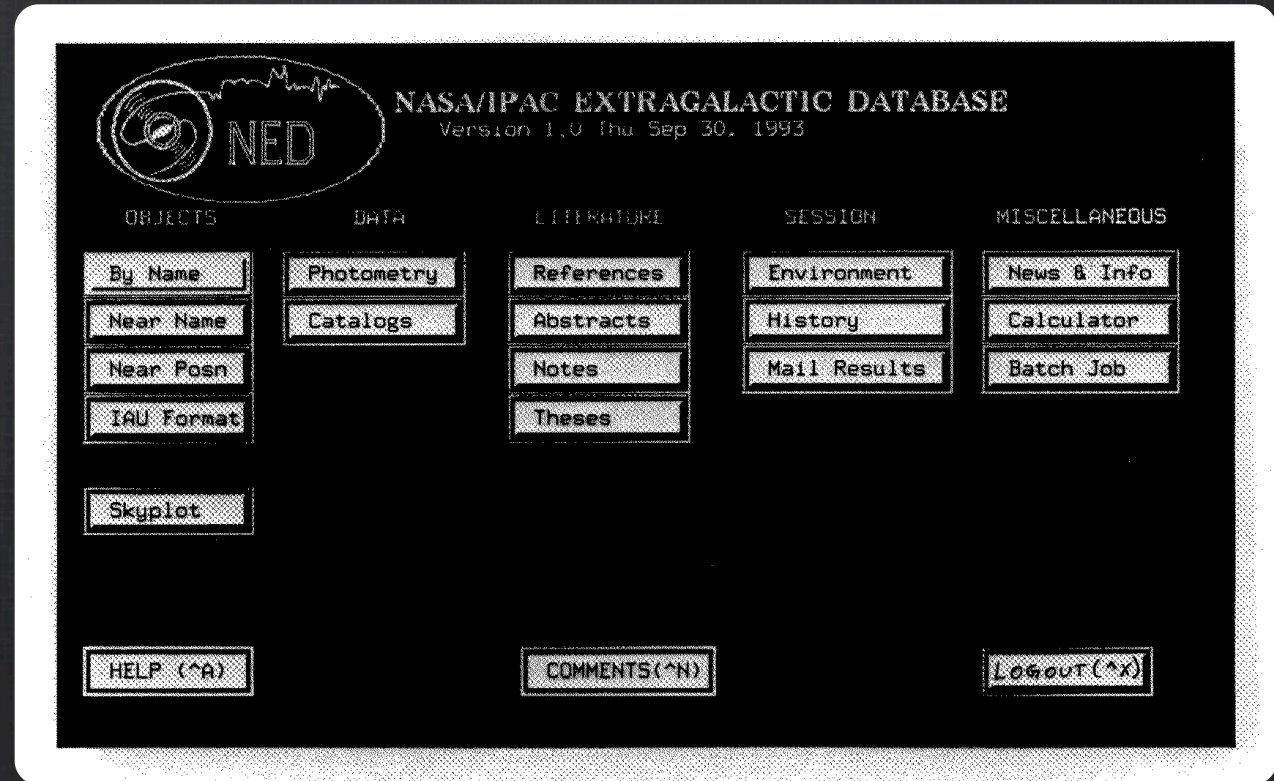



NED

NASA/IPAC EXTRAGALACTIC DATABASE

- ▶ [Latest Updates](#)
- ▶ [Updates to Level5 Knowledgebase](#)
- ▶ [New 2200 HI spectra from Nançay Observations](#)
- ▶ [New Spitzer IRAC and HST ACS images, and VLA maps](#)
- ▶ [Frames](#)



Notice: Ongoing upgrades to the user interface include significant changes to the HTML query reports. Automated queries should use VOTable (XML) output. [Details](#)

OBJECTS	DATA	LITERATURE	TOOLS	INFO
By Name	Images By Object Name or By Region	References by Object Name	Coordinate Transformation & Extinction Calculator Velocity Calculator	FAQ Introduction
Near Name	Photometry & SEDs	References by Author Name	Cosmology Calculators Extinction-Law Calculators	Features Graphical Overview
Near Position	Spectra	Text Search	FTP	NED Source List
Advanced All-Sky	Redshifts	Knowledgebase <small>GAIP/RES. LEVEL 5</small>	X/Y offset to RA/DEC	Team
IAU Format	Positions	Distances	Batch Job Submission	Comment
By Refcode	Notes	Abstracts	Pick Up Batch Job Results	Web Links
	Diameters	Thesis Abstracts	Skyplot	Glossary & Lexicon

Interface last updated: 16 April 2009

Database last updated: 16 April 2009

- 163 million objects
- 170 million multiwavelength object cross-IDs
- 188 thousand associations (candidate cross-IDs)
- 1.4 million redshifts
- 1.7 billion photometric measurements
- 609 million diameter measurements
- 5.0 million objects linked to 68,354 refereed journal articles
- 2.3 million images, maps and external links
- 65 thousand notes
- 45 thousand abstracts
- 56 thousand spectra

If your research benefits from the use of NED, we would appreciate the following acknowledgement in your paper: *This research has made use of the NASA/IPAC Extragalactic Database (NED) which is operated by the Jet Propulsion Laboratory, California Institute of Technology, under contract with the National Aeronautics and Space Administration.*



NED

technology

- stateless: query-report
- 3 interfaces: email, www, nedsrv
 - apache - cgi
 - html, xml, text
 - C, C++, Perl
 - php, python, ruby, fortran can coexist
- IBM-IDS (formerly: Informix OnLine Dynamic server)



NED

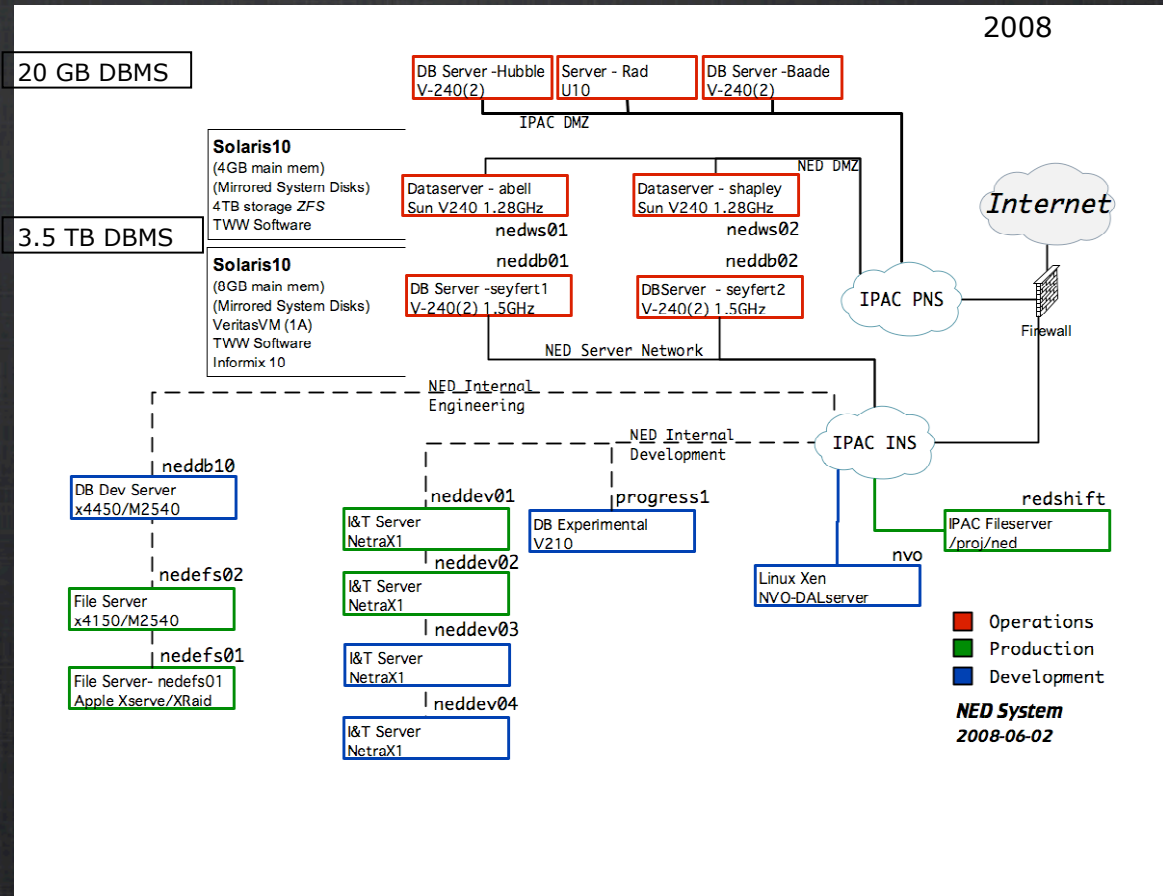



NED

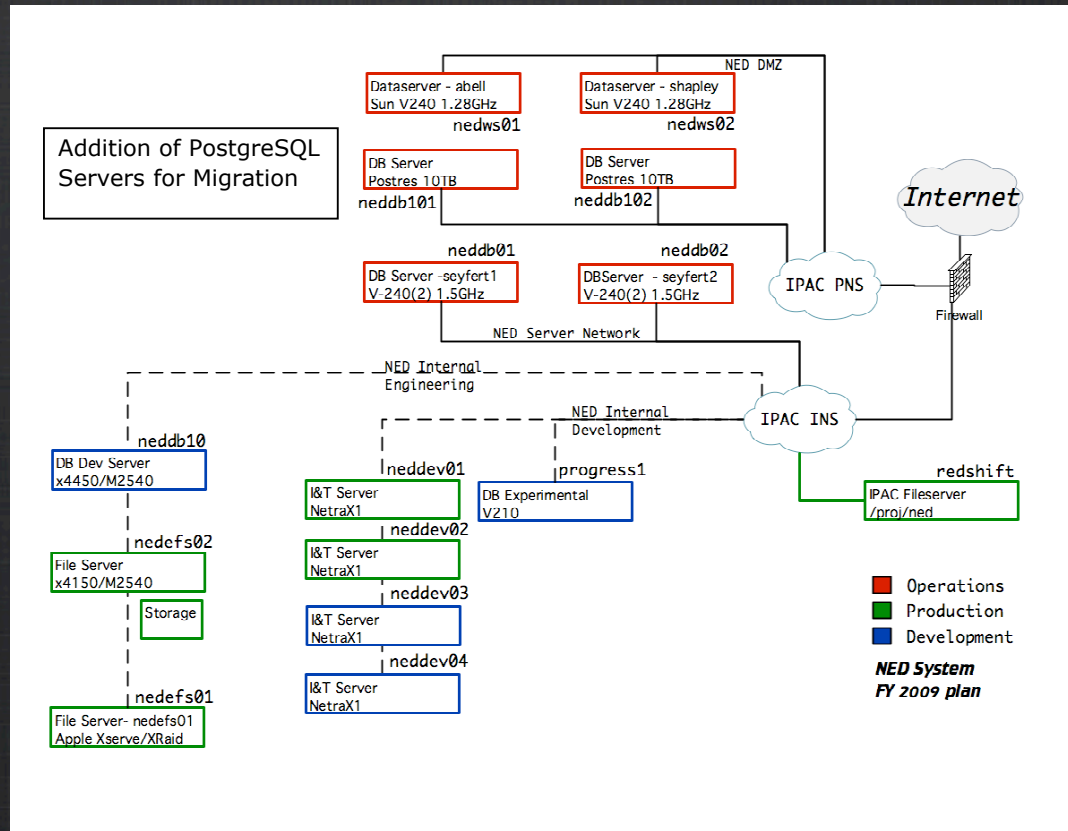



NED

2010 Plan

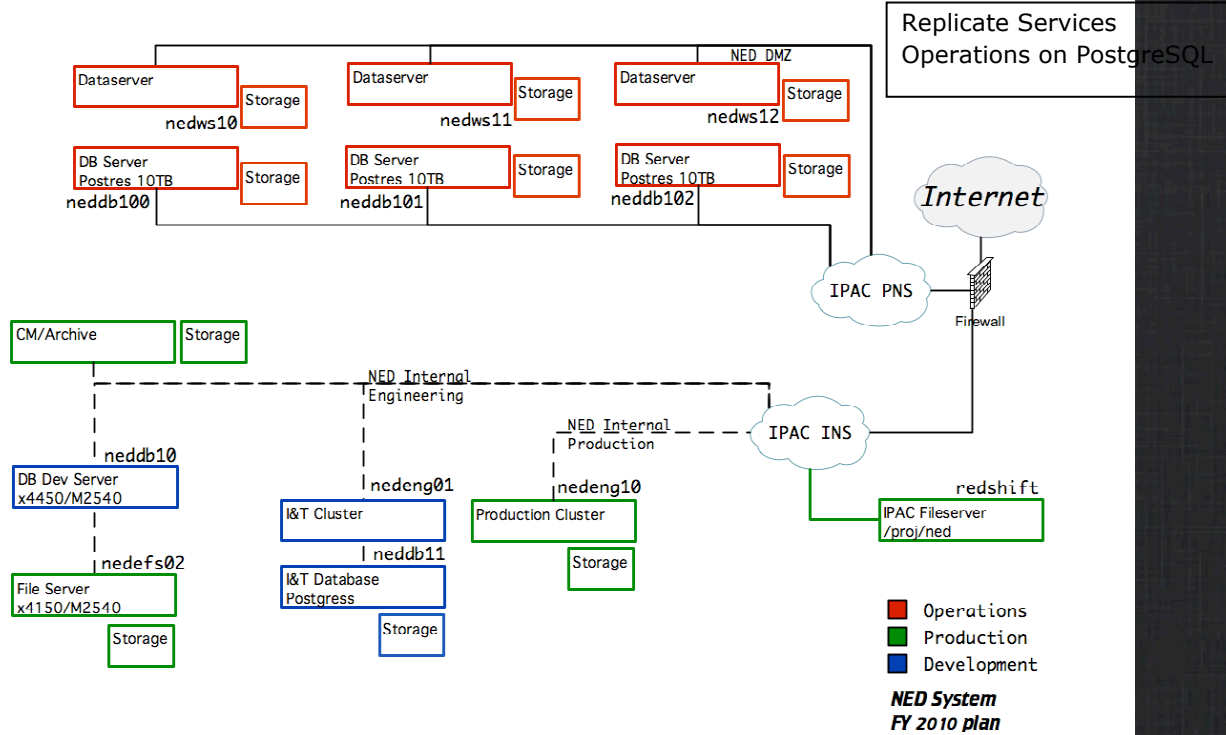



NED

2011-2012 Plan

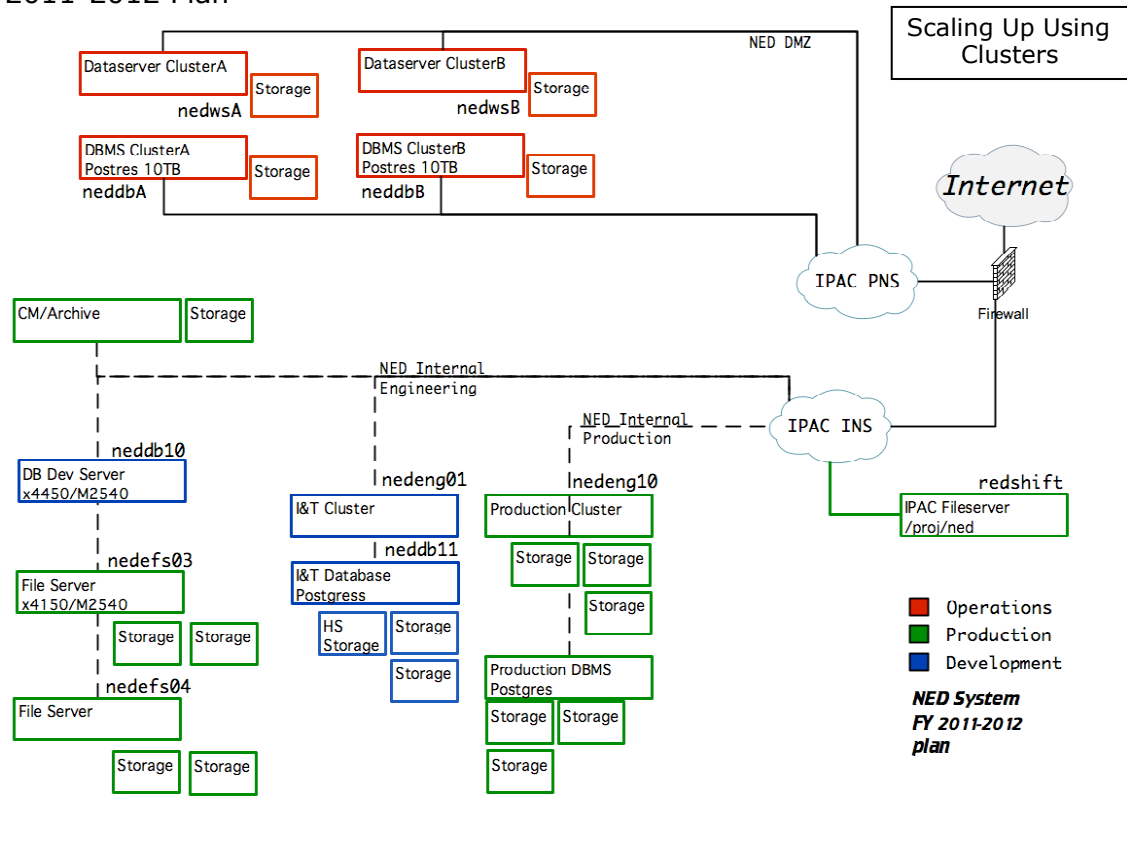



NED

nasa/ipac extragalactic database

Do Not Use for Deployment
or network assignment

NED Internal Development (220)

NED Internal
Engineering (221)

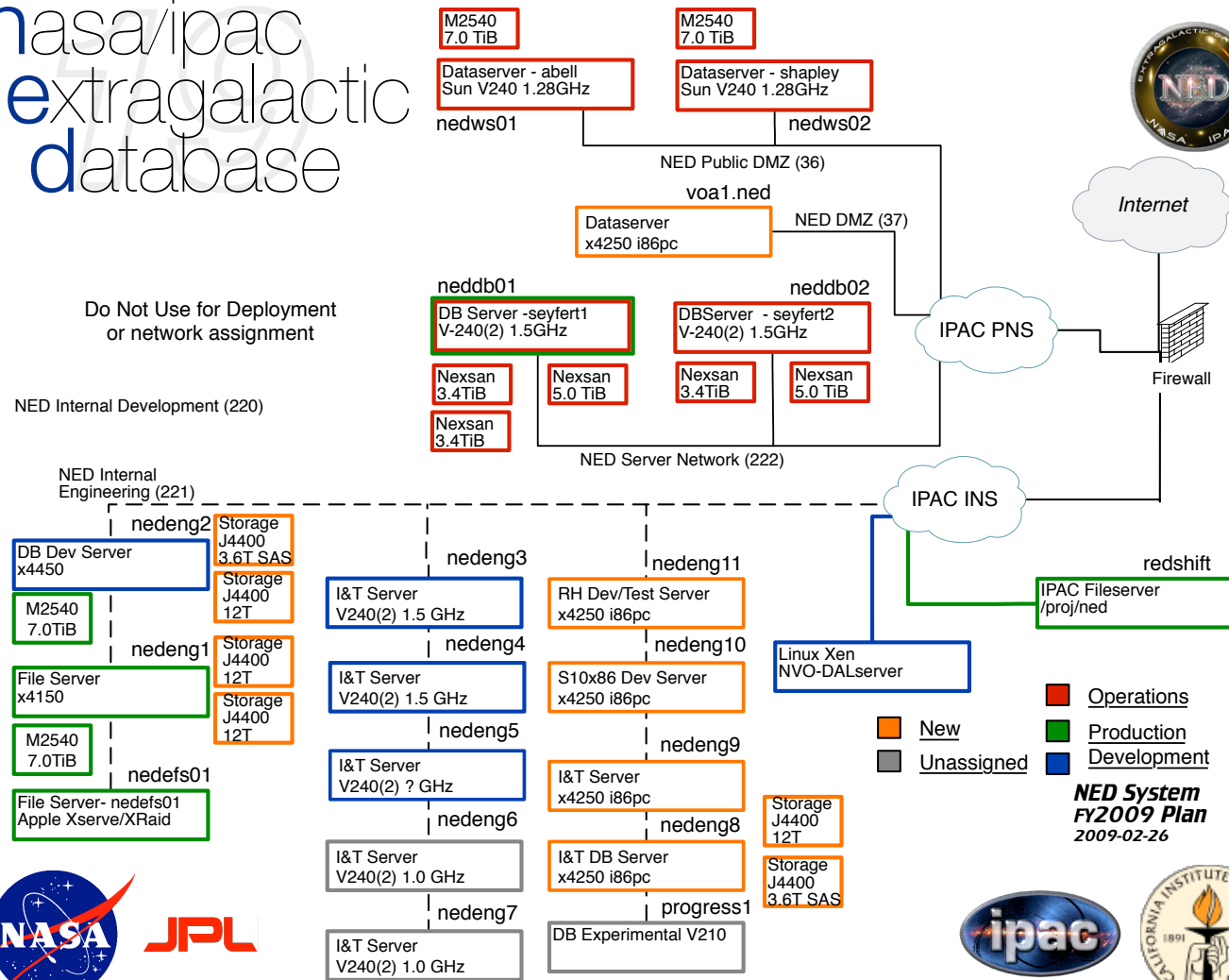



NED

The Future

20





NED

Expected Growth in #Objects

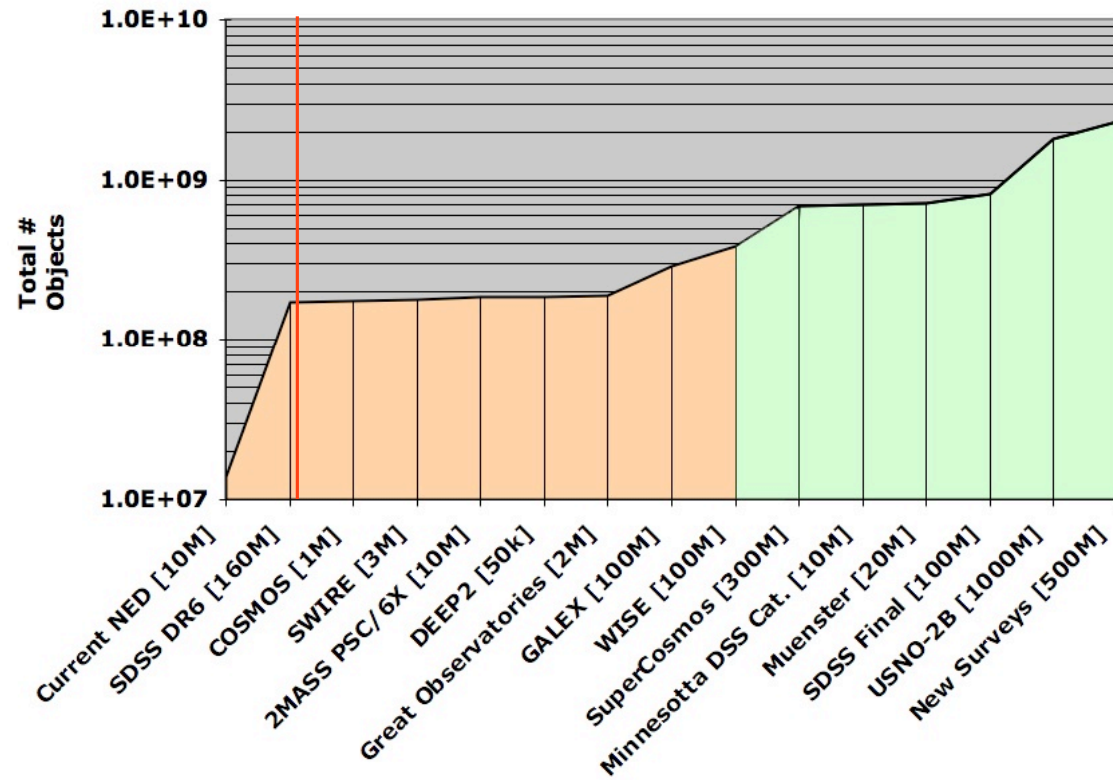



NED

NED is scaling up

- To handle modern sky surveys with hundreds of millions of objects.
- NED has integrated its first 'extremely large' data set (15x):
 - 154 million objects from the Sloan Digital Sky Survey (SDSS) Data Release 6 (DR6) photometric catalog. These are a subset of the 217 million objects in DR6 selected using "Clean sample" filters recommended by the SDSS project
- To handle increased demand of automated queries



NED

Automated usage is continuing to increase:

- Supernovae search preparing for Pan-STARRS (U. Belfast)
- Digital H I Archive group (Cornell)
- PAIRITEL: IR Robotic follow-up of GRB localizations (UC Berkeley)

This is wonderful, but has a significant impact:

- Interactive response time is noticeably degraded
- Requires more user support
- Additional monitoring
- Guidelines for automated use posted online



NED

NED 20

- stateful: interactive sessions, detachable/queue-able queries
- 2? interfaces: www, email?
 - apache - html, xml, text
- and...



NED

The elephant in the room and
the next challenge

ORACLE®

SYBASE®

Microsoft®
SQL Server® 2008

PostgreSQL

MySQL®

INGRES

IBM®
DB2 IDS

PROGRESS
SOFTWARE

D3

ANTs
Software

SQLite



NED

Find the strength in the technology and exploit it;
Find the weakness and avoid it.

- NED has ridden its share of DBMSs
- Capability, Cost, and Longevity
- Exploit, but don't buy in all-the-way
- The decoupled database: Strategies for staying out of the jaws of the DBMS vendors...



NASA/IPAC EXTRAGALACTIC DATABASE

19

